SFP+ 10GBASE-BX 1270nm-TX/1330nm-RX 60km Transceiver
P/N: AE-SFP+-BX60-U

Features

- Supports 9.95 to 11.3Gb/s bit rates
- Simplex LC Connector
- Hot pluggable SFP+ footprint
- Uncooled 1270nm DFB transmitter, 1330nm ADP photo-detector
- Applicable for 60km SMF connection
- Low power consumption, < 1.4W
- Digital Diagnostic Monitor Interface
- Optical interface compliant to IEEE 802.3ae 10GBASE-ER
- Electrical interface compliant to SFF-8431
- Operating case temperature: Commercial: 0 to 70 °C Industrial: -40 to 85 °C

Applications

- 10GBASE-ER at 10.3125Gbps
- 10GBASE-EW at 9.953Gbps
- Other optical link

I. Absolute Maximum Ratings

Parameter	Symbol	Min.	Max.	Unit	Note
Supply Voltage	Vcc	-0.5	4.0	V	
Storage Temperature	TS	-40	85	°C	
Relative Humidity	RH	0	85	%	

Note: Stress in excess of the maximum absolute ratings can cause permanent damage to the transceiver.

II. General Operating Characteristics

Parameter	Symbol	Min.	Typ	Max.	Unit	Note
Data Rate	DR	9.95		10.3125	Gb/s	
Supply Voltage	Vcc	3.13	3.3	3.47	V	
Supply Current	Icc5			430	mA	
Operating Case Temp.	Tc	0		70	°C	
	TI	-40		85		

III. Electrical Characteristics

Parameter	Symbol	Min.	Typ	Max.	Unit	Note
Transmitter						
Differential data input swing	VIN,PP	180		700	mVpp	1
Transmit Disable Voltage	VD	VCC-0.8		Vcc	V	
Transmit Enable Voltage	VEN	Vee		Vee+0.8		
Input differential impedance	Rin		100		Ω	
Receiver						
Differential data output swing	Vout,pp	300		850	mVpp	2
Output rise time and fall time	Tr, Tf	28			Ps	3
LOS asserted	VLOS_F	VCC-0.8		Vcc	V	4
LOS de-asserted	VLOS_N	Vee		Vee+0.8	V	4

Notes:

1. Connected directly to TX data input pins. AC coupling from pins into laser driver IC.
2. Into 100Ω differential termination.
3. 20–80%. Measured with Module Compliance Test Board and OMA test pattern. Use of four 1's and four 0's sequence in the PRBS 9 is an acceptable alternative.
4. LOS is an open collector output. Should be pulled up with 4.7kΩ – 10kΩ on the host board. Normal operation is logic 0; loss of signal is logic 1.

IV. Optical Characteristics

Parameter	Symbol	Min.	Typ	Max.	Unit	Note
Transmitter						
Operating Wavelength	λ	1260	1270	1280	nm	
Ave. output power (Enabled)	PAVE	1		6	dBm	1

Side-Mode Suppression Ratio	SMSR	30			dB	
Extinction Ratio	ER	3.5			dB	
RMS spectral width	$\Delta\lambda$			1	nm	
Rise/Fall time (20%~80%)	Tr/Tf			50	ps	
Dispersion penalty	TDP			3.2	dB	
Relative Intensity Noise	RIN			-128	dB/Hz	
Output Optical Eye	Compliant with IEEE 0802.3ae					
Receiver						
Operating Wavelength	λ	1320	1330	1340	nm	
Receiver Sensitivity	PSEN2			-21	dBm	2
Overload	PAVE			-6	dBm	
Receiver Reflectance	Rrx			-12	dB	
LOS Assert	Pa	-30			dBm	
LOS De-assert	Pd			-21	dBm	
LOS Hysteresis	Pd-Pa	0.5			dB	

Notes:

1. Average power figures are informative only, per IEEE 802.3ae.
2. Measured with worst ER=6; BER<10-12; 231 – 1 PRBS.

V. Pin Definition and Functions

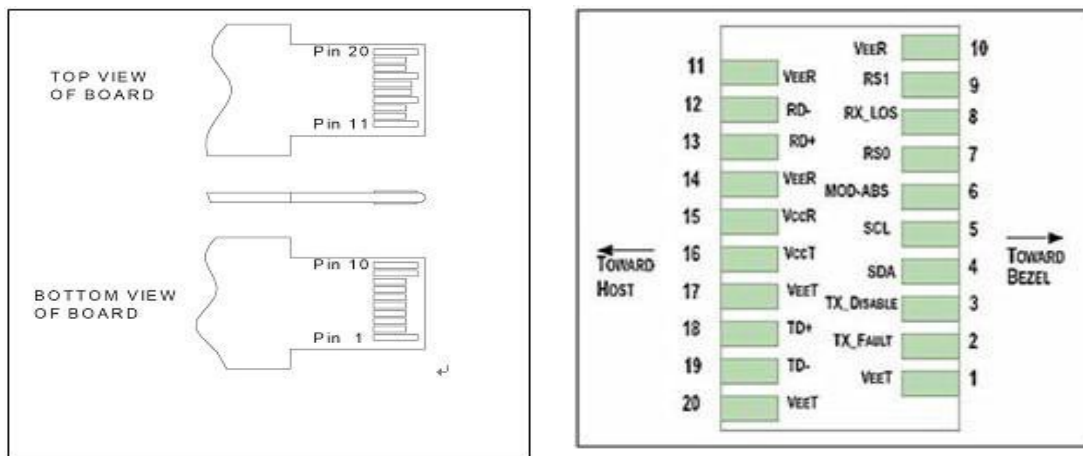

Pin	Symbol	Name/Description
1	VEET [1]	Transmitter Ground
2	Tx_FAULT [2]	Transmitter Fault
3	Tx_DIS [3]	Transmitter Disable. Laser output disabled on high or open
4	SDA [2]	2-wire Serial Interface Data Line
5	SCL [2]	2-wire Serial Interface Clock Line
6	MOD_ABS [4]	Module Absent. Grounded within the module
7	RS0	Rate Select 0

8	RX_LOS [2]	Loss of Signal indication. Logic 0 indicates normal operation
9	RS1 [5]	Rate Select 1
10	VEER [1]	Receiver Ground
11	VEER [1]	Receiver Ground
12	RD-	Receiver Inverted DATA out. AC Coupled
13	RD+	Receiver DATA out. AC Coupled
14	VEER [1]	Receiver Ground
15	VCCR	Receiver Power Supply
16	VCCT	Transmitter Power Supply
17	VEET [1]	Transmitter Ground
18	TD+	Transmitter DATA in. AC Coupled
19	TD-	Transmitter Inverted DATA in. AC Coupled
20	VEET [1]	Transmitter Ground

Notes:

1. Module circuit ground is isolated from module chassis ground within the module.
2. should be pulled up with 4.7k – 10k ohms on host board to a voltage between 3.15V and 3.6V.
3. Tx_Disable is an input contact with a 4.7 k Ω to 10 k Ω pullup to VccT inside the module.
4. Mod_ABS is connected to VeeT or VeeR in the SFP+ module. The host may pull this contact up to Vcc_Host with a resistor in the range 4.7 k Ω to 10 k Ω . Mod_ABS is asserted “High” when the SFP+ module is physically absent from a host slot.

VI. Recommended power supply filter

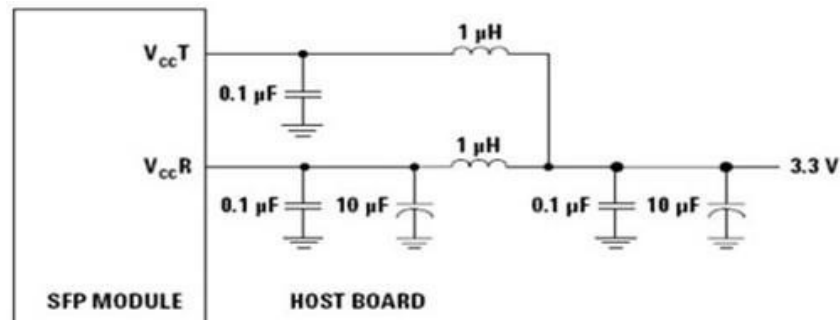

Note:

Inductors with DC resistance of less than 1 Ω should be used in order to maintain the required voltage at the SFP input pin with 3.3V supply voltage. When the recommended supply filtering network is used, hot plugging of the SFP transceiver module will result in an inrush current of no more than 30 mA greater than the steady state value

VII. Ordering Information

Part Number	Description
AE-SFP+-BX60-U	BIDI SFP+, 10 Gb/s, 1270nm, SMF, 60KM, DDM, LC connector, 0°C ~ +70°C
AE-SFP+-BX60-D	BIDI SFP+, 10 Gb/s, 1330nm, SMF, 60KM, DDM, LC connector, 0°C ~ +70°C