

## 25GBASE-BX BIDI SFP28 1310nm-TX/1270nm-RX 40km Transceiver

P/N: AE-SFP28-BX40-D

### Features

- Class 1 laser safety certified
- Operating data rate up to 25.78Gbps
- Up to 40km transmission distance
- High sensitivity APD photodiode and TIA
- LC single connector
- Hot pluggable 20pin connector
- Low power consumption <2W
- 0 to 70°C operating wide temperature range
- Single +3.3V±5% power supply
- Compliant with SFF-8472
- Fully RoHS Compliant

### Applications

- 25GE LR
- CPRI Option 10/e CPRI

### Description

The SFP28 Transceiver is designed for use in Ethernet/e CPRI/ CPRI links up to 25.78 Gb/s data rate and up to 40 km link length.

They are compliant with SFF8472,SFF-8431,SFF-8432. Digital diagnostics functions are available via a 2-wire serial interface, as specified in SFF-8472.

### I. Absolute Maximum Ratings

Parameter	Symbol	Unit	Min	Max
Storage Temperature Range	Ts	°C	-40	85
Relative Humidity	RH	%	0	95
Maximum Supply Voltage	Vcc	V	-0.5	4.0

### II. Recommended Operating Conditions

Parameter	Symbol	Unit	Min	Typ	Max
Operating Case Temperature Range	Tc	°C	0		70

Power Supply Voltage	Vcc	V	3.14	3.3	3.46
Bit Rate	BR	Gb/s		25.78	
Bit Error Ratio	BER				5*10 <sup>-5</sup>
Max Supported Link Length	L	Km			40

### III. Electric Ports Definition

Parameter	Symbol	Unit	Min	Typ	Max	Note
Supply Voltage	VCC	V	3.14	3.3	3.46	
Power Consumption	P	mW			2000	
Transmitter						
Input Differential Impedance	RIN	Ω	90	100	110	
Differential Data Input Swing	VIN	mVp-p	450	600	750	
Transmit Disable Voltage	VDIS	V	2		VCCH OST	
Transmit Enable Voltage	VEN	V	VEE		VEE+0. 8	
Transmit Fault Assert Voltage	VFA	V	2		VCCH OST	
Transmit Fault De-Assert Voltage	VFDA	V	VEE		VEE+0. 4	
Receiver						
Output Differential Impedance	ROUT	Ω	90	100	110	
Differential Data Output Swing	VOD	mVp-p	450	600	750	
LOS Fault	VLOSFT	V	2		VCCH OST	
LOS Normal	VLOSNR	V	VEE		VEE+0. 4	

### IV. Optical Characteristics (Tc=0 to 70 oC and Vcc= 3.14 to 3.46V)

Parameter	Symbol	Unit	Min	Typ	Max	Note
Transmitter Parameters						
Nominal Wavelength	λ	nm	1300	1310	1320	
Average Output Power	Pav	dBm	-2		6	
Spectral Width (-20dB)		nm			1	
Extinction Ratio	ER	dB	3.5			
Side Mode Suppression Ratio	SMSR	dB	30			
Average Launch Power of OFF Transmitter	POFF	dBm			-30	
Relative Intensity Noise	RIN	dB/H z			-128	
Receiver Parameters						

Center Wavelength	$\lambda$ C	nm	1260	1270	1280	
Receiver Sensitivity	RSENSE	dBm			-19	1
Receiver Overload	PMAX	dBm	-5			
Optical Return Loss		dB			-26	
LOS Assert	LOSA	dBm	-35			
LOS De-Assert LOS	LOSD	dBm			-20	
LOS Hysteresis		dB	0.5			

Note1: Measured at 25.78125Gb/s, ER>3.5dBm, PRBS 231-1 and BER better than or equal to 5E-5;

### V. Pin function definitions

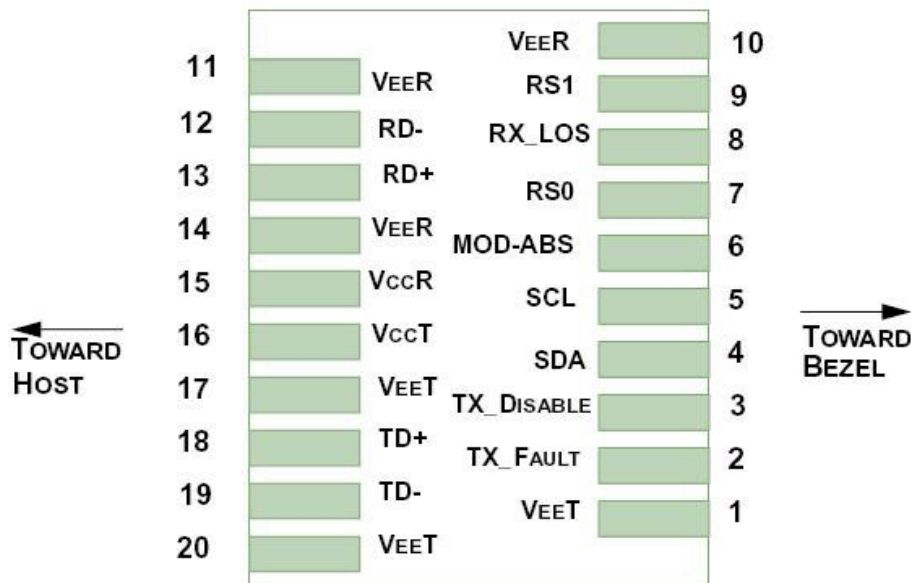

Figure 1. Pin function finitions

Pin Number	Symbol	Name	Description
1,17,20	VeeT	Transmitter Signal Ground	These pins should be connected to signal ground on the host board.
2	TX Fault	Transmitter Fault Out (OC)	Logic “1” Output = Laser Fault (Laser off before t_fault) Logic “0” Output = Normal Operation This pin is open collector compatible, and should be pulled up to Host Vcc with a 10kΩ resistor.
3	TX Disable	Transmitter Disable In (LVTTTL)	Logic “1” Input (or no connection) = Laser off Logic “0” Input = Laser on This pin is internally pulled up to VccT with a 10 kΩ resistor.
4	SDA	Module Definition Identifiers	Serial ID with SFF 8472 Diagnostics Module Definition pins should be pulled up to Host Vcc with 10 kΩ resistors.
5	SCL		
6	MOD-A		

	BS		
7	RS0	Receiver Rate Select (LVTTTL) Transmitter Rate Select (LVTTTL)	These pins have an internal 30kΩ pull-down to ground. A signal on either of these pins will not affect module performance.
9	RS1		
8	LOS	Loss of Signal Out (OC)	Sufficient optical signal for potential BER < 1x10 <sup>-12</sup> = Logic "0" Insufficient optical signal for potential BER > 1x10 <sup>-12</sup> = Logic "1" This pin is open collector compatible, and should be pulled up to Host Vcc with a 10kΩ resistor.
10,11,14	VeeR	Receiver Signal Ground	These pins should be connected to signal ground on the host board.
12	RD-	Receiver Negative DATA Out (CML)	Light on = Logic "0" Output Receiver DATA output is internally AC coupled and series terminated with a 50Ω resistor.
13	RD+	Receiver Positive DATA Out (CML)	Light on = Logic "1" Output Receiver DATA output is internally AC coupled and series terminated with a 50Ω resistor.
15	VccR	Receiver Power Supply	This pin should be connected to a filtered +3.3V power supply on the host board. See Figure 3.Recommended power supply filter
16	VccT	Transmitter Power Supply	This pin should be connected to a filtered +3.3V power supply on the host board. See Figure 3.Recommended power supply filter
18	TD+	Transmitter Positive DATA In (CML)	Logic "1" Input = Light on Transmitter DATA inputs are internally AC coupled and terminated with a differential 100Ω resistor.
19	TD-	Transmitter Negative DATA In (CML)	Logic "0" Input = Light on Transmitter DATA inputs are internally AC coupled and terminated with a differential 100Ω resistor.

## VI. Typical Application Circuit

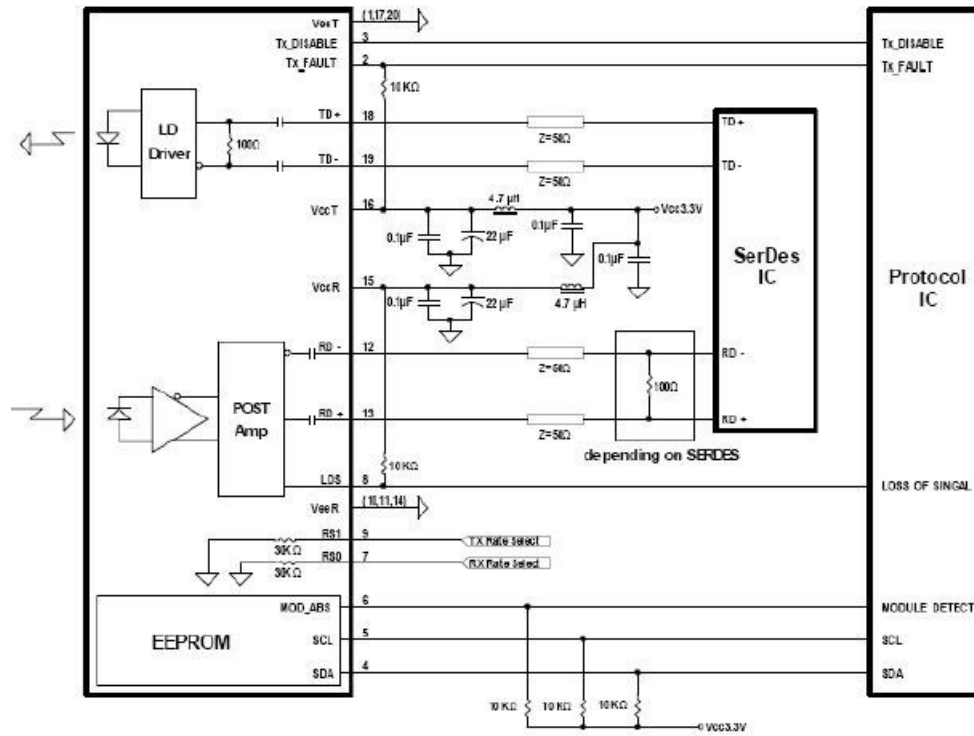

Figure 2. Typical application circuit

## VII. Ordering information

Part Number	Product Description
AE-SFP28-BX40-D	1310nm-TX/1270nm-RX, 25Gbps, LC, 40km, 0°C~+70°C, with DDM