

SFP Bi-Directional GPON ONU Transceiver

Product Features

- BiDi SFP Single Mode Transceiver
- SC receptacle
- Comply with ITU-T G.984.5 Class B+
- Compliant with SFP MSA And SFF-8472 V10.3
- Single +3.3 Power Supply
- CML Differential Data Inputs and LVPECL Data Outputs
- LVTTTL Signal Detection Output And LVTTTL Burst Control
- Complies with Telecordia (Bellcore) GR-468-CORE
- 1310 nm Burst Mode Transmitter and 1490 nm Continuous Mode Receiver
- 1.244 Gbps DFB Laser Diode, 2.488Gbps APD-TIA Receiver
- Maximal reach 20km

Product Applications

- GPON ONU For P2MP Application

General

The AERECH AE0342034-KxSx transceiver with SFP package supports typically Tx 1.244Gbps and Rx2.488Gbps Asymmetric Data Rate for GPON ONU application up to 20km transmission distance, it's designed meeting with ITU-T G.984.5 Class B+. SC receptacle is for optical interface.

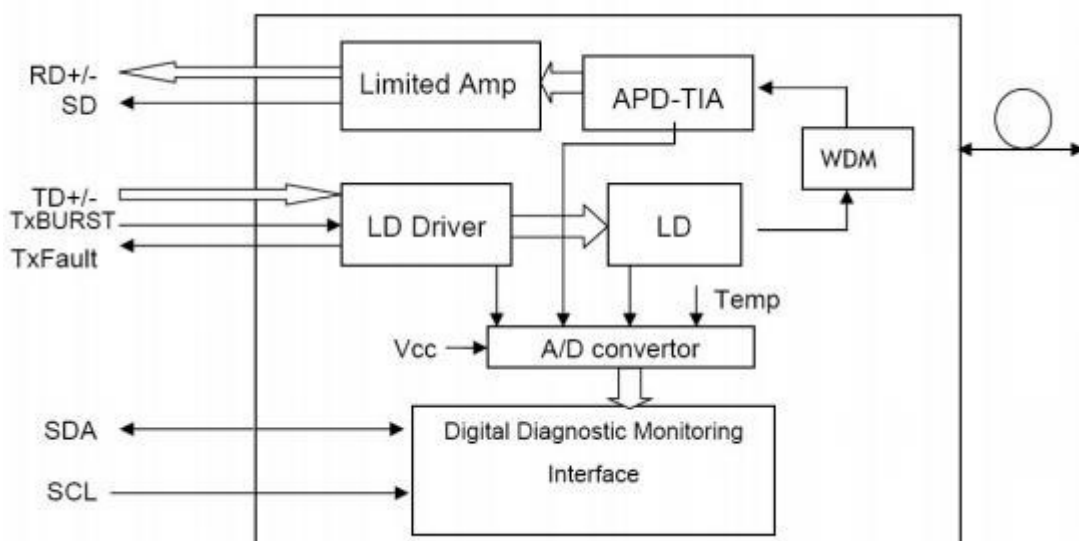

Fig 1 Transceiver Block Diagram

The module provides digital diagnostic information of its operating conditions and status, including transmitting power, laser bias, receiver input optical power, module temperature, and supply voltage. Calibration and alarm/warning threshold data are written and stored in internal memory (EEPROM). The memory map is compatible with SFF-8472, as shown in Fig. 2. The diagnostic data are raw A/D values and must be converted to real world units using calibration constants stored in EEPROM locations 56 – 95 in A2h.

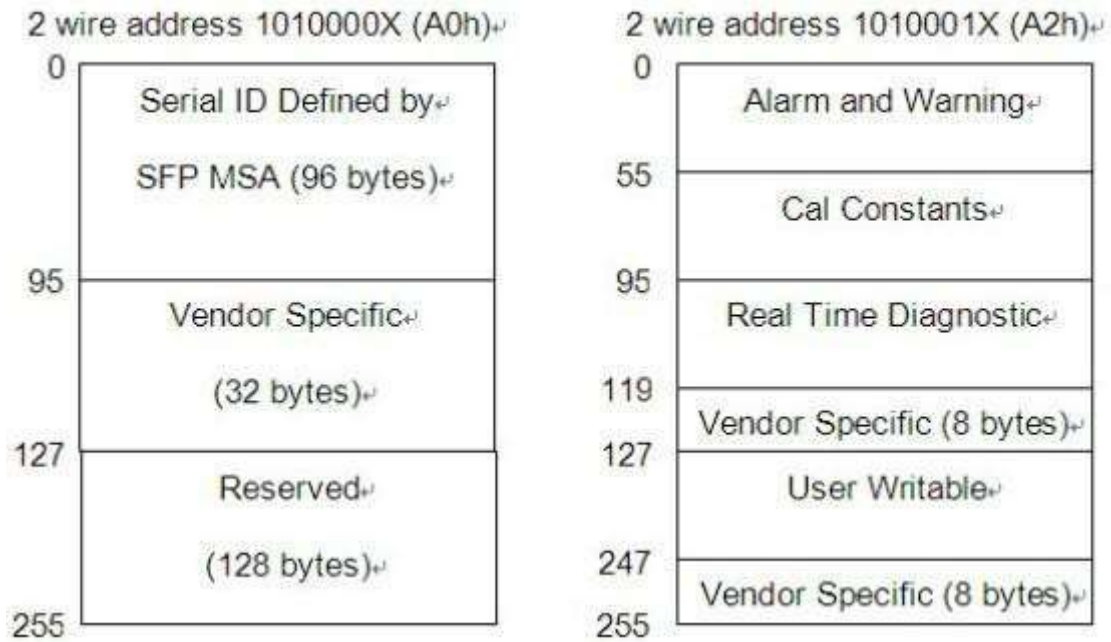

Fig 2 EEPROM Information

Performance Specifications

Absolute Maximum Ratings					
Parameter	Symbol	Min.	Max.	Unit	Note
Storage Temperature	Tst	-40	+85	°C	
Operating Case Temperature	Tc	0	70	°C	AE0342034-KxSx
		-40	+85		AE0342034-KISx
Input Voltage	-	GND	Vcc	V	
Power Supply Voltage	Vcc-Vee	-0.5	+3.6	V	
Damage Threshold For Receiver	-	-	4	dBm	
Soldering Temperature / Time	-	-	260/10	°C/S	

Recommended Operating Conditions						
Parameter	Symbol	Min.	Typical	Max.	Unit	Note
Power Supply Voltage	Vcc	3.135	3.3	3.465	V	-
Operating Case Temperature	Tc	0	-	70	°C	AE0342034-KxSx
		-40	-	85		AE0342034-KISx
Total Supply Current	-	-	-	350	mA	-

Optical Specification							
Transmitter							
Parameter	Symbol	Min.	Typ.	Max.	Unit	Note	
Data Rate	DR	-	1.244	-	Gbps	-	-
Optical Central Wavelength	λ	1260	1310	1360	nm		
Spectral Width (-20dB)	$\Delta\lambda$	-	-	1	nm		
Side Mode Suppression Ratio	SMSR	30	-	-	dB		
Average Optical Output Power	Po	0.5	-	5	dBm		
Extinction Ratio	Er	10	-	-	dB	-	
Transmitter Reflectance	-	-	-	-12	dB		
Tx Burst ON Time	Ton	-	-	12.8	ns	-	
Tx Burst OFF Time	Toff	-	-	12.8	ns	-	
Rise/Fall Time	Tr/Tf	-	-	250	ps	-	
Average Launched Power of Off Transmitter	Poff	-	-	-45	dBm	-	
Output Eye	Compliant with ITU-T G.984.2						
Receiver							
Parameter	Symbol	Min.	Typ.	Max.	Unit	Note	
Data Rate	DR	-	2.488	-	Gbps	-	-
Operate Wavelength	-	1480	-	1500	nm	-	
Sensitivity	Pr	-	-	-28	dBm	1	
Saturation	Ps	-8	-	-	dBm	1	
SD De-assert Level	-	-45	-	-	dBm	-	
SD Assert Level	-	-	-	-28	dBm	-	
SD Hysteresis	-	0.5	-	6	dB	-	
Receiver Reflectance	-	-	-	-12	dB	-	
RSSI Range	-	-28	-	-8	dBm		
RSSI Accuracy	-	-3	-	+3	dB		

Note:

1. Minimum Sensitivity and saturation levels for a 2²³-1 PRBS. BER≤10⁻¹⁰, 2.488Gpbs, ER=9dB

Electrical Specification						
Transmitter						
Parameter	Symbol	Min.	Typ.	Max.	Unit	Note
Differential Input Voltage	V _{IN-DIF}	200		1600	mV	-
Tx Burst Input Voltage-Low	V _{IL}	0		0.8	V	-
Tx Burst Input Voltage-High	V _{IH}	2.0		V _{CC}	V	-
Receiver						
Parameter	Symbol	Min.	Typ.	Max.	Unit	Note
Data Output Voltage Differential	V _{OUT-DIF}	400	-	1000	V	-
Signal Detect Output Voltage-Low	V _{SD-L}	0	-	0.8	V	-
Signal Detect Output Voltage-High	V _{SD-H}	2.0	-	V _{CC}	V	

EEPROM Information

EEPROM Serial ID Memory Contents (A0h)

Addr. (decimal)	Field Size (Bytes)	Name of Field	Content (Hex)	Content (Decimal)	Description
0	1	Identifier	03	3	SFP
1	1	Ext. Identifier	04	4	MOD4
2	1	Connector	01	01	Receptacle
3-10	8	Transceiver	00 00 00 00 00 00 00 00	00 00 00 00 00 00 00 00	Not defined
11	1	Encoding	03	3	NRZ
12	1	BR, nominal	0C	12	1.25Gbps
13	1	Reserved	00	0	-
14	1	Length (9um)-km	14	20	20km
15	1	Length (9um)	C8	200	20km
16	1	Length (50um)	00	0	-
17	1	Length (62.5um)	00	0	-
18	1	Length (copper)	00	0	-
19	1	Reserved	00	0	-
20-35	16	Vendor name	5A 4B 54 45 4C 20 20 20 20 20 20 20 20 20 20 20	90 75 84 69 76 32 32 32 32 32 32 32 32 32 32 32	'AERECH' (ASCII)
36	1	Reserved	00	0	-
37-39	3	Vendor OUI	00 00 00	0 0 0	-
40-55	16	Vendor PN	5A 50 35 33 34 32	90 80 53 51 52	AE0342034-KxSx

GPON ONU SFP

			30 33 34 2D B xx 53 xx 20 20	50 48 51 52 45 5 xx 83 xx 32 32	(ASCII)
56-59	4	Vendor rev	30 30 30 20	48 48 48 32	"000" (ASCII)
60-61	2	Wavelength	05 1E	05 30	1310
62	1	Reserved	00	0	-
63	1	CC BASE	-	-	Check sum of bytes 0 - 62
64	1	Reserved	00	0	
65	1	Options	1A	26	
66	1	BR, max	00	0	-
67	1	BR, min	00	0	-
68-83	16	Vendor SN	-	-	ASCII
84-91	8	Vendor date	-	-	Year (2 bytes), Month (2 bytes), Day (2 bytes)
92	1	DDM Type	58/68	88/104	External/Internal Calibrated
93	1	Enhanced Option	B0	176	LOS, TX_FAULT and Alarm/warning flags implemented
94	1	SFF-8472 Compliance	03	3	SFF-8472 Rev 10.3
95	1	CC EXT	-	-	Check sum of bytes 64 - 94
96-255	160	Vendor spec			

Alarm and Warning Thresholds (Serial ID A2H)

Parameter (Unit)	C Temp (°C)	I Temp (°C)	Voltage (V)	Bias (mA)	TX Power (dBm)	RX Power (dBm)
High Alarm	100	100	3.6	90	6	-7
Low Alarm	-10	-40	3	0	-0.5	-29
High Warning	95	95	3.5	70	5	-8
Low Warning	0	-30	3.1	0	0.5	-28

Digital Diagnostic Monitor Accuracy

Parameter	Unit	Accuracy	Range	Calibration
Tx Optical Power	dB	±3	Po: -Pomin~Pomax dBm, Recommended operation conditions	External/Internal
Rx Optical Power	dB	±3	Pi: Ps~Pr dBm, Recommended operation conditions	External/Internal
Bias Current	%	±10	Id: 1-100mA, Recommended operating conditions	External/Internal
Power Supply Voltage	%	±3	Recommended operating conditions	External/Internal
Internal Temperature	°C	±3	Recommended operating conditions	External/Internal

PIN Diagram

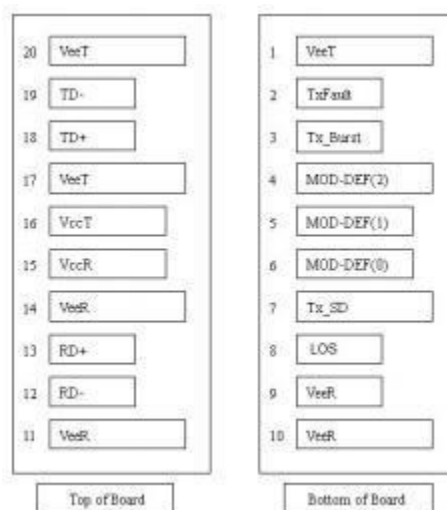

PIN Description

Pin No.	Name	Function	Plug Seq.	Notes
1	VeeT	Transmitter Ground	1	
2	Tx Fault	Transmitter Fault Indication	3	Note 1
3	Tx_Burst	Transmitter Burst Mode Control. Burst Logic '1' or Logic '0' Tx on	3	Note 2
4	MOD-DEF2	Module Definition 2	3	Note 3
5	MOD-DEF1	Module Definition 1	3	Note 3
6	MOD-DEF0	Module Definition 0	3	Note 3
7	Tx_SD	Tx Transmitter State Indication, assert When Tx ON .Optional	3	Note 4
8	LOS	Los Of Signal	3	Note 5
9	VeeR	Receiver Ground	1	Note 6

10	VeeR	Receiver Ground	1	Note 6
11	VeeR	Receiver Ground	1	Note 6
12	RD-	Inv. Receiver Data Out	3	Note 7
13	RD+	Receiver Data Out	3	Note 7
14	VeeR	Receiver Ground	1	Note 6
15	VccR	Receiver Power Supply	2	Note 8, 3.3V 5%
16	VccT	Transmitter Power Supply	2	Note 8, 3.3V 5%
17	VeeT	Transmitter Ground	1	Note 6
18	TD+	Transmitter Data In	3	Note 9
19	TD-	Inv. Transmitter Data In	3	Note 9
20	VeeT	Transmitter Ground	1	Note 6

Notes:

1. TX Fault is an open collector/drain output, which should be pulled up with a 4.7K–10KΩ resistor on the host board. Pull up voltage between 2.0V and VccT, R+0.3V. When high, output indicates a laser fault of some kind. Low indicates normal operation. In the low state, the output will be pulled to < 0.8V.
2. Tx_Burst is a TTL input. When it is low, LD is on; when it is high, LD is off.
3. Mod-Def 0,1,2. These are the module definition pins. They should be pulled up with a 4.7K– 10KΩ resistor on the host board. The pull-up voltage shall be VccT or VccR.
 Mod-Def 0 is grounded by the module to indicate that the module is present
 Mod-Def 1 is the clock line of two wire serial interface for serial ID
 Mod-Def 2 is the data line of two wire serial interface for serial ID
4. Tx_SD is a Tx Signal Detect. If there are signal, TX Active State: High.
5. LOS (Loss of Signal) is an open collector/drain output, which should be pulled up with a 4.7K – 10KΩ resistor. Pull up voltage between 2.0V and VccT, R+0.3V. When high, this output indicates the received optical power is below the worst-case receiver sensitivity (as defined by the standard in use). Low indicates normal operation. In the low state, the output will be pulled to < 0.8V.
6. VeeR and VeeT may be internally connected within the SFP module.
7. RD-/+ : These are the differential receiver outputs. They are AC coupled 100Ω differential lines which should be terminated with 100Ω (differential) at the user SERDES. The AC coupling is done inside the module and is thus not required on the host board.
8. VccR and VccT are the receiver and transmitter power supplies. They are defined as 3.3V±5% at the SFP connector pin. Maximum supply current is 300mA. Recommended host board power supply filtering is shown below. Inductors with DC resistance of less than 1Ω should be used in order to maintain the required voltage at the SFP input pin with 3.3V supply voltage. When the recommended supply filtering network is used, hot plugging of the SFP transceiver module will result in an inrush current of no more than 30 mA greater than the steady state value. VccR and VccT may be internally connected within the SFP transceiver module.
9. TD-/+ : These are the differential transmitter inputs. They are AC-coupled, differential lines with 100Ω differential termination inside the module. The AC coupling is done inside the module and is thus not required on the host board.

Recommended Circuit

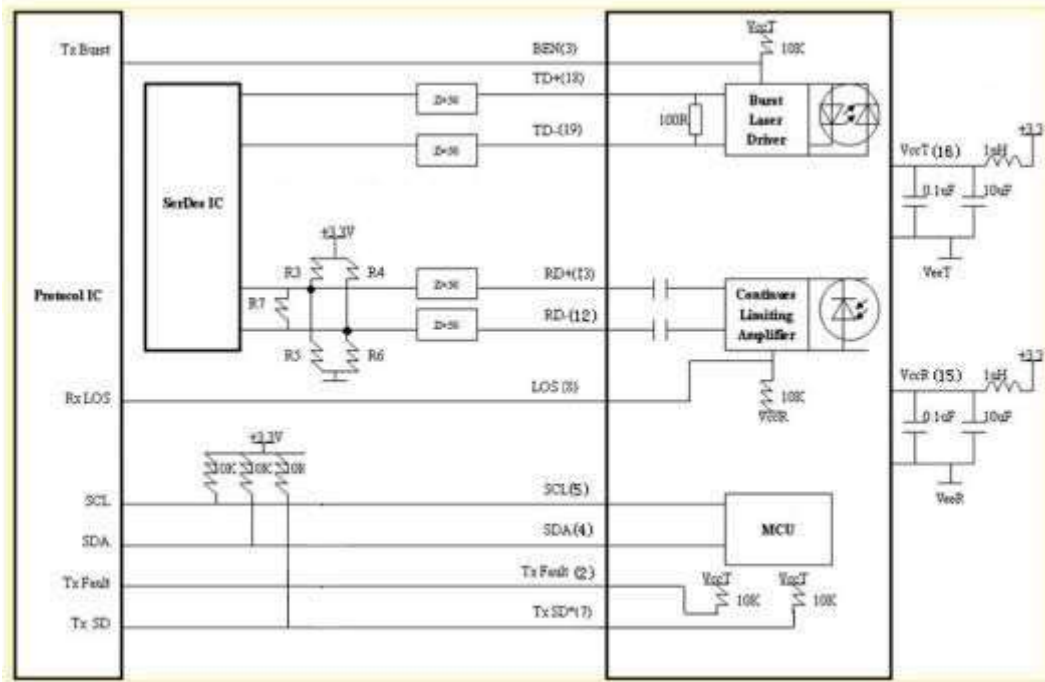

Note:

Tx : DC coupled internally.

Rx : AC coupled internally.

Input stage in SerDes IC with internal bias to Vcc-1.3V

$R3=R4=R5=R6=N.C$, $R7=100\Omega$

Input stage in SerDes IC without internal bias to Vcc-1.3V

$R3=R4=82\Omega$, $R5=R6=130\Omega$, $R7=N.C$

Burst Mode Sequence Definition

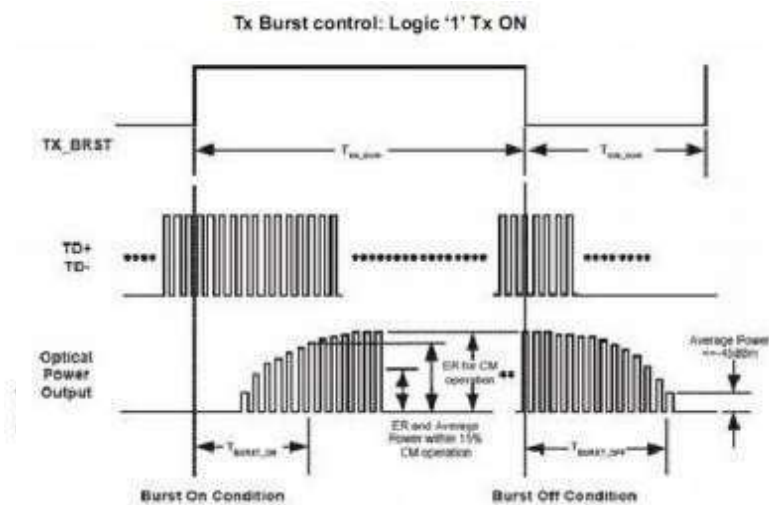

Package Diagram

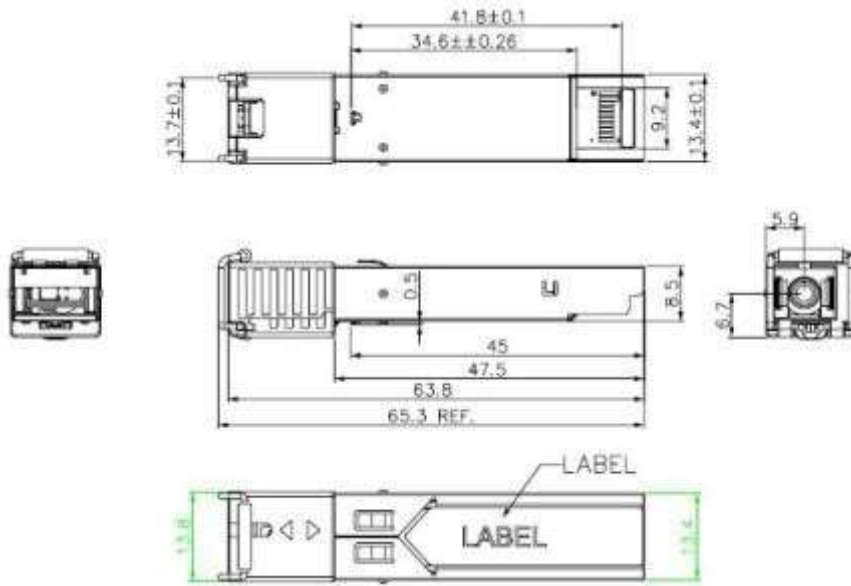

Unit: mm